



FG

120

Power
10 kW

Max weld surface
-

Max weldable electrode width
-

Free space behind electrode
-

Daylight (with 45 mm tall electrode)
-

Power requirement - max/hour
3.7 kW/h

Main fuse - type D
32 A

Working frequency
27.12 MHz





TP 120 and CP9

TP 120

The TP is an accessory available for the FG 120 and has a maximum electrode length of 300 mm. TP 120 is ideal for small detailed welds, such as reinforcement bands around a large structure.

CP9

The CP9 is a single-sided punching and welding of eyelets. It stands as an advanced HF welding machine designed to streamline your production process by integrating setting, punching, and welding into a single, seamless operation.

Extras

Computer and Software

Data transfer program
Travel programs
Control programs

Material positioning

Band holder
Magnet system
Vacuum system
Laser lines

Welding tools

Electrodes
Impulse welding unit
Tube-closing tools
Supplementary tool

Other

Cooling
Welding table

Dimensions

Front

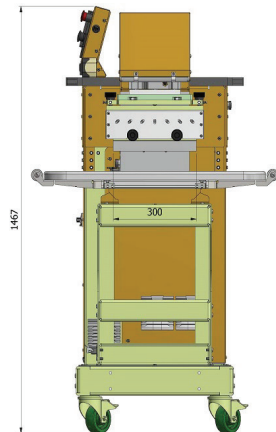

Side

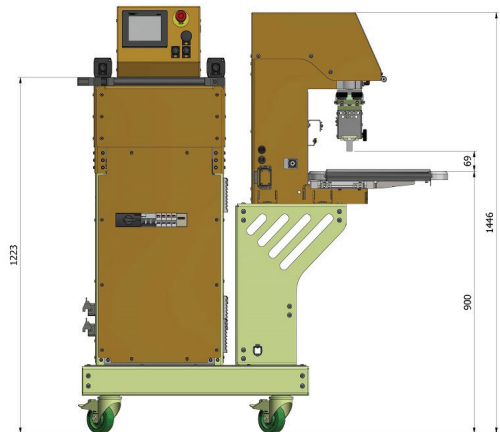

forsstrom.com/machine/generator-fg-120

Learn more about the benefits of having the Forsstrom FG as part of your production.

Call or email Forsstrom sales:

Tel: +46 523 66 66 00

sales@forsstrom.com

All machines are manufactured on order according to customer specification. We make sure it is equipped to make your production as efficient as possible.