



TG-90

300

Power
8 kW

Max weld surface
300 cm²

Max electrode width
600 mm

Daylight
80 mm

Power requirement
5.5 kW/h

Main fuse - type D
32 A

Working frequency
27.12 MHz

400

Power
10 kW

Max weld surface
400 cm²

Max electrode width
600 mm

Daylight
80 mm

Power requirement
5.8 kW/h

Main fuse - type D
32 A

Working frequency
27.12 MHz

500

Power
12 kW

Max weld surface
500 cm²

Max electrode width
600 mm

Daylight
80 mm

Power requirement
6.2 kW/h

Main fuse - type D
32 A

Working frequency
27.12 MHz

650

Power
16 kW

Max weld surface
650 cm²

Max electrode width
600 mm

Daylight
80 mm

Power requirement
6.9 kW/h

Main fuse - type D
63 A

Working frequency
27.12 MHz

800

Power
20 kW

Max weld surface
800 cm²

Max electrode width
600 mm

Daylight
80 mm

Power requirement
7.6 kW/h

Main fuse - type D
63 A

Working frequency
27.12 MHz

1000

Power
25 kW

Max weld surface
1000 cm²

Max electrode width
600 mm

Daylight
80 mm

Power requirement
9.2 kW/h

Main fuse - type D
63 A

Working frequency
27.12 MHz





Operating system and Software

Operating system

The operating system is developed by Forsstrom programmers and sales representatives with experience in the field. It is a system developed for welders by welders. The computer features a 12" touch screen.

Software

Forsstrom iQ is designed to monitor and analyze users' HF/RF welding department. Powerful reporting tools allow quick identification of weak points and bottlenecks resulting in optimal usage of production capacities.

Extras

Computer and Software

Data transfer program
Travel programs
Control programs

Material positioning

Band holder
Magnet system
Vacuum system
Laser lines

Welding tools

Electrodes
Impulse welding unit
Tube-closing tools
Supplementary tool

Other

Cooling
Welding table

Dimensions

Front

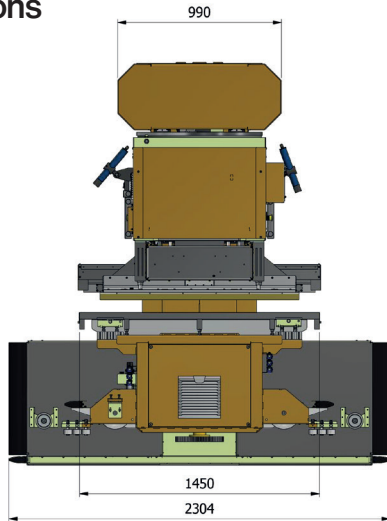

Side

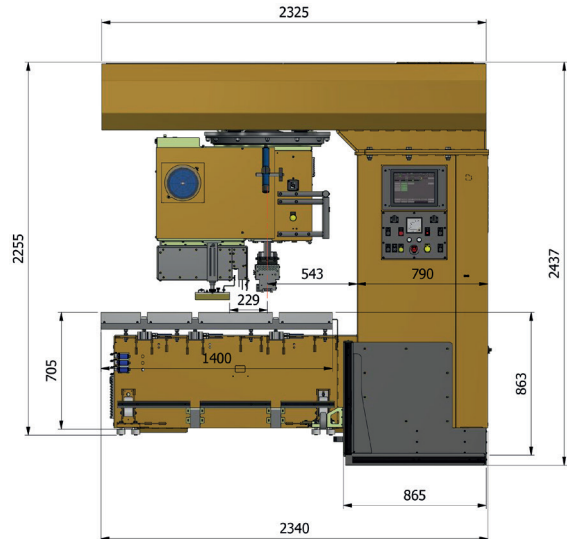

forsstrom.com/machine/tg-90-mega-300-1000

Learn more about the benefits of having the Forsstrom TG-90 as part of your production.

Call or email Forsstrom sales:

Tel: +46 523 66 66 00

sales@forsstrom.com

All machines are manufactured on order according to customer specification. We make sure it is equipped to make your production as efficient as possible.