

# CP9

## New and Improved

### Eyelet change

The CP9 features a redesigned eyelet change mechanism for effortless operation. Backed by Forsstrom's service team, the CP9 sets a new standard in reliability and performance.

### HF Generator

The FG 120 is a small 3kW HF-generator with built-in control system for controlling welding parameters. It is suitable as a stand-alone unit for eyelet welding.

## Electrodes for eyelets

11/27



11/28



13/32



15/37



19/43



## Loading stations

11/27



11/28



13/32



15/37



19/43



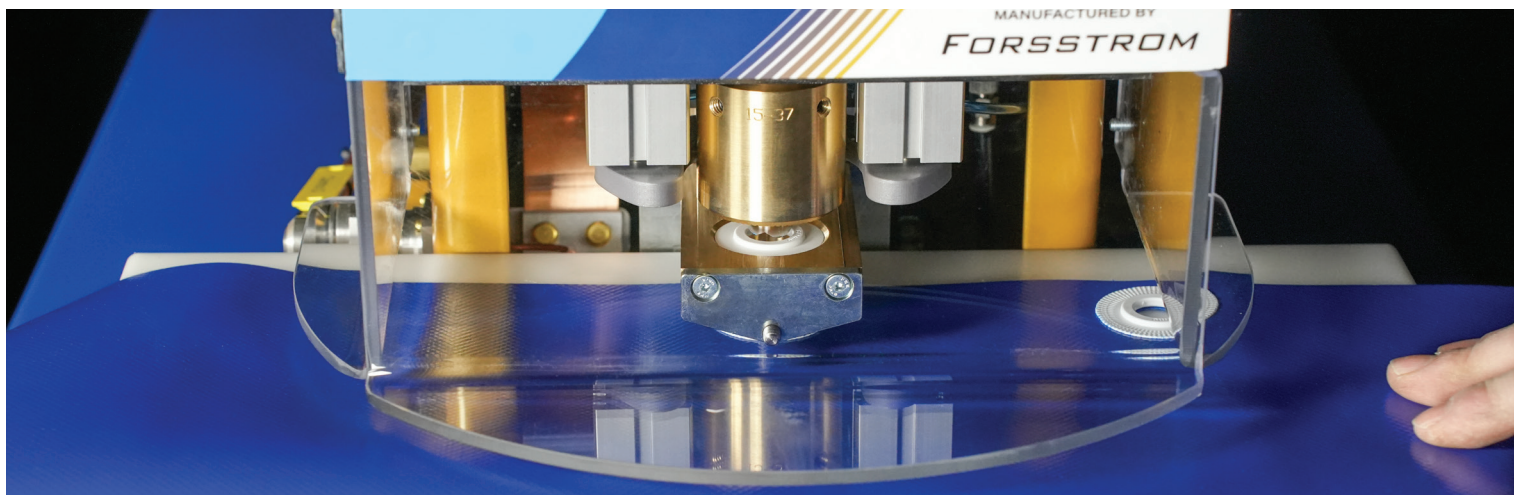

## Technical specifications

**Standard voltage**  
230 VAC

**Fuse max**  
13 A

**Frequency**  
50 Hz

**Pressure**  
6.4-10 bar

**Max electricity consumption**  
1 A

**Litre air per minute**  
25 l/m

**Working Frequency**  
27.12 MHz

## Dimensions

Front

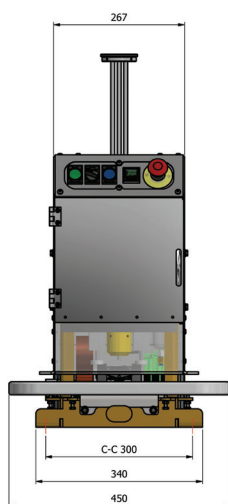

Side

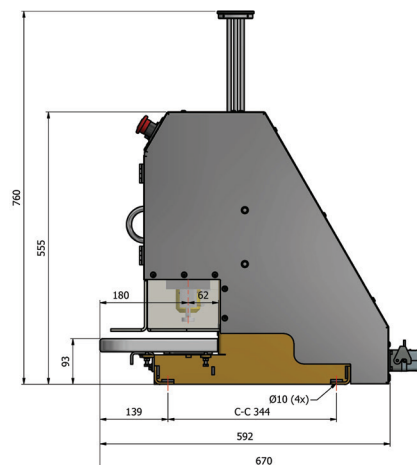

[forsstrom.com/machine/cp9](https://forsstrom.com/machine/cp9)

Learn more about the benefits of having the Forsstrom x Carmo CP9 as part of your production.

Call or email Forsstrom sales:  
Tel: +46 523 66 66 00  
[sales@forsstrom.com](mailto:sales@forsstrom.com)

All machines are manufactured on order according to customer specification.  
We make sure it is equipped to make your production as efficient as possible.